



ETA-Danmark A/S
Göteborg Plads 1
DK-2150 Nordhavn
Tel. +45 72 24 59 00
Fax +45 72 24 59 04
Internet www.etadanmark.dk

Authorised and notified according
to Article 29 of the Regulation (EU)
No 305/2011 of the European
Parliament and of the Council of 9
March 2011

MEMBER OF EOTA



European Technical Assessment ETA-21/0568 of 2021/07/13

I General Part

Technical Assessment Body issuing the ETA and designated according to Article 29 of the Regulation (EU) No 305/2011: ETA-Danmark A/S

Trade name of the construction product:

best wood CLT

Product family to which the above construction product belongs:

Cross laminated timber element

Manufacturer:

Holzwerk Gebr. Schneider GmbH
Kappel 28
DE-88436 Eberhardzell
www.schneider-holz.com

Manufacturing plant:

Holzwerk Gebr. Schneider GmbH
Kappel 28
DE-88436 Eberhardzell

This European Technical Assessment contains:

16 pages including 4 annexes which form an integral part of the document

This European Technical Assessment is issued in accordance with Regulation (EU) No 305/2011, on the basis of:

EAD 130005-00-0304 - Solid wood slab element for use as structural element in buildings

This version replaces:

Translations of this European Technical Assessment in other languages shall fully correspond to the original issued document and should be identified as such.

Communication of this European Technical Assessment, including transmission by electronic means, shall be in full (excepted the confidential Annex(es) referred to above). However, partial reproduction may be made, with the written consent of the issuing Technical Assessment Body. Any partial reproduction has to be identified as such.

II SPECIFIC PART OF THE EUROPEAN TECHNICAL ASSESSMENT

1 Technical description of product

Technical description of the product

„best wood CLT” is a cross laminated timber element made of softwood consisting of at least 3 layers. The lay-up of the cross laminated timber shall be approximately symmetrical to its centre plane. A layup is considered symmetrical, if the distance between the centre of gravity of the element cross-section and the centre plane does not exceed 3% of the thickness of the cross laminated timber element. Also additional, non-load-bearing layers from softwood or European hardwood which are added for reasons of aesthetics or fire resistance are accepted.

The elements are plane.

Individual layers consist of parallel oriented lamellae made of strength graded boards or resawn strength graded boards. In elements with at least five layers, up to three adjacent layers with a total thickness not exceeding 90 mm may be oriented with parallel grain direction.

The components and the system setup of the product are given in Annex 1, Figure 1 and Figure 2.

The application of chemical substances (wood preservatives and flame retardants) is not subject of the European technical assessment.

Wood species are spruce or fir.

2 Specification of the intended use in accordance with the applicable European Assessment Document (hereinafter EAD)

The cross laminated timber is intended to be used as a structural or non-structural element in buildings and timber structures. The cross laminated timber shall be subjected to static and quasi static actions only. This includes seismic actions according to EN 1998-1.

The cross laminated timber is intended to be used in service classes 1 and 2 according to EN 1995-1-1. Members which are directly exposed to the weather shall be provided with an effective protection for the cross laminated timber element in service.

The performances given in Section 3 are only valid if the cross laminated timber elements are used in compliance with the specifications and conditions given in Annex 1 to 5.

The provisions made in this European Technical Assessment are based on an assumed intended working life of the wood slab elements of 50 years.

The real working life may be, in normal conditions, considerably longer without major degradation affecting the essential requirements of the works.

The indications given on the working life cannot be interpreted as a guarantee given by the producer or Assessment Body, but are to be regarded only as a means for choosing the right products in relation to the expected economically reasonable working life of the works.

3 Performance of the product and references to the methods used for its assessment

Characteristic	Assessment of characteristic
3.1 Mechanical resistance and stability (BWR1)¹⁾	
Bending ²⁾	Annex 3
Tension and compression ²⁾	Annex 3
Shear ²⁾	Annex 3
Embedment strength	Annex 3
Creep and duration of the load	Annex 3
Dimensional stability	Annex 3
In-service environment	Annex 3
Bond integrity	Annex 3
3.2 Safety in case of fire (BWR2)	
Reaction to fire	Euroclass D-s2,d0 Euroclass D _{fl} -s1
Resistance to fire Charring rate	$\beta_0 = 0,65$ mm/min $\beta_n = 0,7$ mm/min
3.3 Hygiene, health and the environment (BWR3)	
Content, emission and/or release of dangerous substances	Release scenarios: IA 1, IA2 The manufacturer has submitted a written declaration to ETA Danmark A/S that no dangerous substances > 0.1 wt. % are used in the product assessed by the present ETA. The use of wood preservatives and flame retardants is excluded. The chemical composition of the adhesives for gluing the boards and the finger joints of the individual boards has to be in compliance with the chemical composition deposited at ETA Danmark A/S.
Water vapour permeability – Water vapour transmission	No performance assessed
3.4 Safety in use (BWR4)	
Impact resistance	Soft body resistance is assumed to be fulfilled for walls with a minimum of 3 layers and minimum thickness of 60 mm.
3.5 Protection against noise (BWR5)	No performance assessed
3.6 Energy economy and heat retention (BWR6)	
	The design value of thermal conductivity to be used in design calculations of the solid wood slab is $\lambda = 0,12$ W/(mK).

¹⁾ This characteristic also relates to BWR 4

²⁾ Load bearing capacity and stiffness regarding mechanical actions perpendicular to and in plane of the cross laminated timber element.

3.7 Mechanical resistance and stability

For gluing the layers among each other to form a cross laminated timber element as well as the finger joints of the individual boards an adhesive type I according to EN 15425 is to be used. Specifications are deposited with ETA Danmark A/S.

3.8 Aspects related to the performance of the product

The cross laminated timber elements are manufactured in accordance with the provisions of this European Technical Assessment using the automated manufacturing process in accordance with the technical documentation.

The layers shall be bonded together to the required thickness of the cross laminated timber.

Specifications of the used boards are given in Annex 2. Boards are visually or machine strength graded and may be resawn after machine strength grading. The influence of resawing on the strength grade shall be taken into account. Only technically dried wood shall be used.

The boards may be connected by finger joints in longitudinal direction according to EN 14080. There shall be no butt joints.

The cross laminated timber elements correspond to the specifications given in Annexes 1 to 3 of this European technical assessment. The material characteristics, dimensions and tolerances of the cross laminated timber elements not indicated in these Annexes are given in the technical documentation of the European Technical Assessment.

Design

The European Technical Assessment only applies to the manufacture and use of cross laminated timber elements. Verification of stability of the building while using the cross laminated timber elements is not subject of the European Technical Assessment.

The following conditions shall be observed:

- Design of the cross laminated timber elements is carried out under the responsibility of an engineer experienced in such products.
- Design of the works shall account for the protection of the cross laminated timber elements.
- The cross laminated timber elements are installed correctly.

Design of the cross laminated timber element can be performed according to EN 1995-1-1 and EN 1998-1, taking into account Annexes 2 to 5 of the European

Technical Assessment. Standards and regulations valid in the place of use shall be considered.

Execution of construction works

The cross laminated timber elements shall be protected during transport and storage against any damage and detrimental moisture effects. The manufacturer's instructions for packaging transport and storage shall be observed.

The assessment of the fitness for use is based on the assumption that maintenance is not required during the assumed intended working life. In case of a severe damage of a cross laminated timber element immediate actions regarding the mechanical resistance and stability of the works shall be initiated. Should this situation arise replacement of the elements can be necessary.

The manufacturer shall prepare assembling instructions in which the product-specific characteristics and important measures to be taken into consideration for assembling are described. The assembling instructions shall be available at every construction site.

The assembling of the cross laminated timber elements according to this European technical assessment shall be carried out by appropriately qualified personnel.

Cross laminated timber elements shall be protected against detrimental change of moisture. The safety-at-work and health protection regulations have to be observed.

4 Attestation and verification of constancy of performance (AVCP)

4.1 AVCP system

According to the Decision 97/176/EC of the European Commission, as amended by 2001/596/EC, the system of assessment and verification of constancy of performance (see Annex V to the regulation (EU) No 305/2011) is System 1.

5 Technical details necessary for the implementation of the AVCP system, as foreseen in the applicable EAD

Technical details necessary for the implementation of the AVCP system are laid down in the control plan deposited at ETA-Danmark prior to CE marking

Issued in Copenhagen on 2021-07-13 by



Thomas Bruun
Managing Director, ETA-Danmark

Annex 1
Construction of the wood slab elements „best wood CLT” (example)

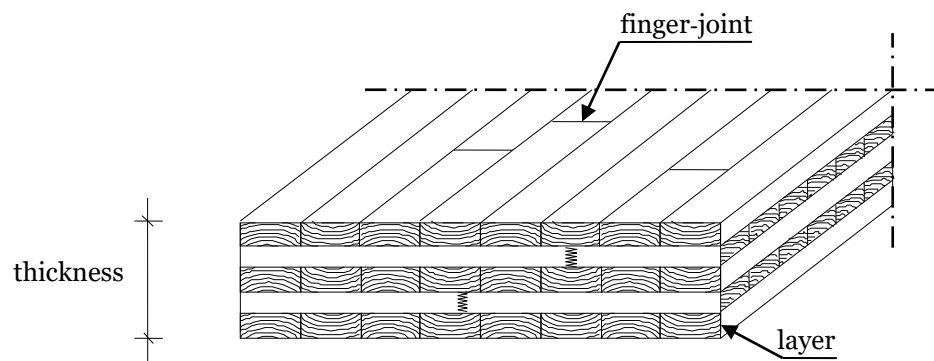

Figure 1: Principle structure of the cross laminated timber (five layers)

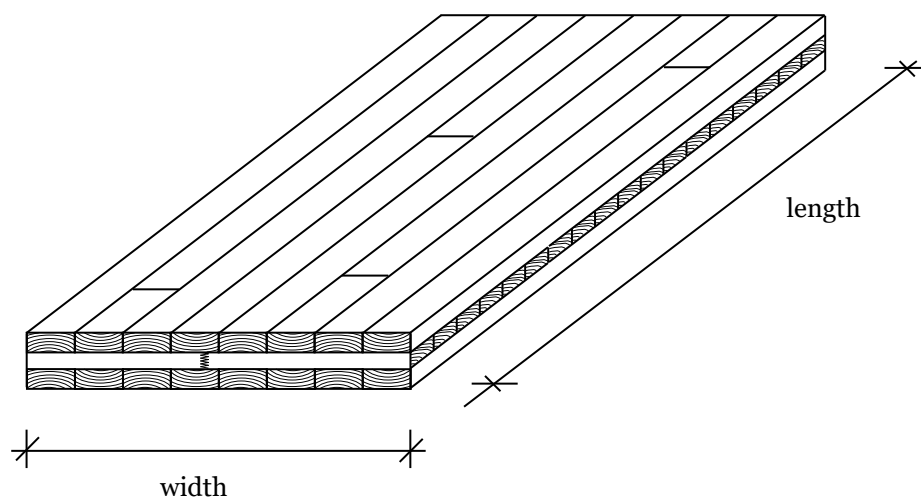

Figure 2: Cross laminated timber element (three layers)

Annex 2
Dimensions and specifications of the cross laminated timber

Characteristic	Dimensions and specifications
Cross laminated timber element	
Thickness	36 to 350 mm
Tolerance in thickness	± 1 mm
Width	$\leq 4,50$ m
Tolerance in width	± 3 mm
Length	$\leq 25,00$ m
Tolerance in length	± 3 mm
Number of layers	≥ 3
Number of consecutive layers having the same grain direction	≤ 3 for $n \geq 5$
Maximum width of gaps between adjacent boards in longitudinal or cross layers	2 mm
Boards	
Material	softwood
Strength class according to EN 338	$\geq T10$ or $\geq C16$
Thickness t	6 to 40 mm
Width b	40 to 300 mm
Ratio width b to thickness t of non-edge glued cross-layers	$b/t \geq 4:1$
Moisture of wood according to EN 13183-2	6% to 15% Within one cross laminated timber element the moisture content difference between single boards is limited to 5%
Finger joints	EN 14080

Annex 3
Design principles of the cross laminated timber elements

Table 2: Essential Requirements of the cross laminated timber

ER	Requirement	Verification method	Class / Use category / value	
1	Mechanical resistance and stability			
	For the calculation the characteristic strength and stiffness values of softwood according to EN 338 shall be used taking into consideration the definitions in annex 2. In addition the following values apply:			
	Board strength class	EN 338	C16/T10 C24/T14 C27/T16 C30/T18	
	Modulus of elasticity parallel to grain of the boards $E_{0,mean}$	EAD 130005-00-0304 2.2.1.1	C24/T14 C27/T16	12000 MPa 12000 MPa
	Bending strength parallel to grain of the boards $f_{m,k}$	EAD 130005-00-0304 2.2.1.1	C16/T10 C24/T14 C27/T16 C30/T18	$k_{sys} \cdot 16$ MPa $k_{sys} \cdot 24$ MPa $k_{sys} \cdot 27$ MPa $k_{sys} \cdot 30$ MPa
	Density ρ_k	EAD 130005-00-0304	C16/T10 C24/T14 C27/T16 C30/T18	$1,1 \cdot 310$ kg/m ³ $1,1 \cdot 350$ kg/m ³ $1,1 \cdot 360$ kg/m ³ $1,1 \cdot 380$ kg/m ³
	1.1 Mechanical actions in plane of the cross laminated timber			
	Shear strength for the calculation with the gross cross section $f_{v,gross,k}$	EAD 130005-00-0304 2.2.1.3	C16/T10 C24/T14 C27/T16 C30/T18	3,2 MPa 4,0 MPa 4,0 MPa 4,0 MPa
	Shear strength for the calculation in the joints between non-edge glued boards within a layer $f_{v,net,k}$	EAD 130005-00-0304 2.2.1.3		8,0 MPa
	Shear strength for the calculation in the crossing areas of orthogonally bonded non-edge glued boards $f_{v,tor,k}$	EAD 130005-00-0304 2.2.1.3		2,5 MPa
	1.2 Mechanical actions perpendicular to the plane of the cross laminated timber			
	Rolling shear strength $f_{R,k}$	EAD 130005-00-0304 2.2.1.3		See Figure 3
	Rolling shear modulus $G_{90,mean}$	EAD 130005-00-0304 2.2.1.3		50 MPa
	Compression strength $f_{c,90,k}$	EAD 130005-00-0304	C16/T10 C24/T14 C27/T16 C30/T18	2,5 MPa 3,0 MPa 3,0 MPa 3,0 MPa
	For references regarding the calculation see below. National regulations might have to be followed.			
	Use of fasteners	According to EN 1995-1-1, for further details see annex 4		
	Creep and duration of load	According to EN 1995-1-1		
Dimensional stability	Moisture content during use shall not change to such extent that adverse deformations can occur.			

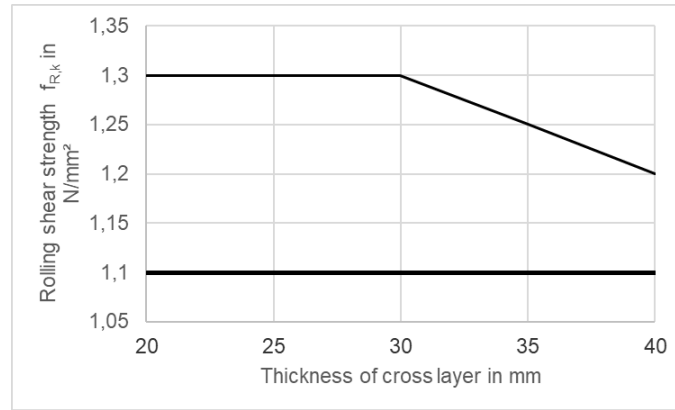

Figure 3: Rolling shear strength $f_{R,k}$ for edge glued cross layers (top line, $1,2 \text{ N/mm}^2 \leq f_{R,k} \leq 1,3 \text{ N/mm}^2$) and non-edge glued cross layers (bottom line, $f_{R,k} = 1,1 \text{ N/mm}^2$)

1.1 Mechanical actions in plane of the cross laminated timber

Stress distribution within the element has to be calculated by taking into account only the boards which are oriented in the direction of the actions.

Shear stresses may be calculated with the total width of the cross laminated timber and must not exceed $f_{v,d}$, where $f_{v,k}$ is defined as:

$$f_{v,k} = \min \left\{ f_{v,gross,k}; f_{v,net,k} \cdot \frac{t_{net}}{t_{tot}}; f_{v,tor,k} \cdot \frac{1}{6 \cdot t_{tot}} \cdot \sum_{i=1}^{n-1} \frac{b_i^2 + b_{i+1}^2}{a_i} \right\}$$

with t_{net} = lower accumulated thickness of longitudinal or cross layers, respectively.

t_{tot} = thickness of cross laminated timber element, or accumulated thickness of longitudinal and cross layers.

n = number of board layers within cross laminated timber element. Adjacent parallel layers are considered as one layer.

b_i = board width in layer i

b_{i+1} = board width in layer $i + 1$

a_i = $\max \{b_i; b_{i+1}\}$

For cross laminated timber members with edge-glued layers, the third expression in the definition of $f_{v,k}$ may be disregarded.

For the design of cross laminated timber elements made of layers of softwood the characteristic strength and stiffness values of the layers of softwood shall be taken from Table 2.

For the verification of the bending strength the design bending strength value of a layer of boards may be multiplied by a system strength factor k_{sys}

$$k_{sys} = \min \begin{cases} 0,975 + 0,025 \cdot n_\ell \\ 1,2 \end{cases}$$

with n_ℓ = number of longitudinal layers.

1.2 Mechanical actions perpendicular to the plane of the cross laminated timber

Stress distribution within the cross laminated timber has to be calculated taking into account the shear deformation of the cross layers.

For simply supported cross laminated timber elements with up to 5 layers the stress distribution may be calculated according to EN 1995-1-1 as mechanically jointed beam where the value s_i/K_i is substituted by $d_i/(G b)$ with d_i = thickness of the cross layer, G = rolling shear modulus of the cross layer $G_{90,mean}$ and b = width of the cross layer.

For cross laminated timber with more than 5 layers, numerical solutions offered by computer programs may be used taking into account the shear deformation of the cross layers.

For the design of cross laminated timber, the characteristic strength and stiffness values shall be taken from Table 2.

For the bending design only the stresses at the edges of the boards are decisive, axial stresses in the centre of the boards are not considered in the design.

In bending design, the characteristic bending strength properties may be multiplied by a system strength factor k_{sys}

$$k_{\text{sys}} = \min \begin{cases} 0,975 + 0,025 \cdot n_{\ell} \\ 1,2 \end{cases}$$

with n_{ℓ} = number of boards within the outermost longitudinal layer

Tension loads perpendicular to the element should be avoided.

Annex 4 Design of connections with mechanical fasteners

General

The design rules given in this section amend the design rules for connections given in EN 1995-1-1. Plane sides are the surfaces of the element parallel to the plane of the element, narrow sides are the surfaces perpendicular to the plane sides of the element.

1.1 Laterally loaded dowel type fasteners

1.1.1 Joints in the plane side of cross laminated timber

Embedding strength:

For nails, self-tapping screws, dowels and bolts in the plane side of cross laminated timber the embedding strength of solid timber may be used, depending on the characteristic density of the laminations of the cross laminated timber and on the angle between force and grain direction of the outer layer.

The following conditions shall be fulfilled:

- Diameter of nails $d \geq 4$ mm
- Diameter of self-tapping screws $d \geq 6$ mm

Effective number of fasteners:

The effective number of fasteners n_{ef} for outer layers with a thickness ≤ 40 mm shall be taken from equation (1)

$$F_o \quad n_{ef} = n \quad (1)$$

For outer layers with a thickness $t_{lay} > 40$ mm the effective number of fasteners n_{ef} for solid timber shall be used.

Minimum spacings, edge and end distances:

Minimum spacings, edge and end distances and angle α between the force and the grain direction of the outer layers as defined in Figure 4 are given in Table 4.

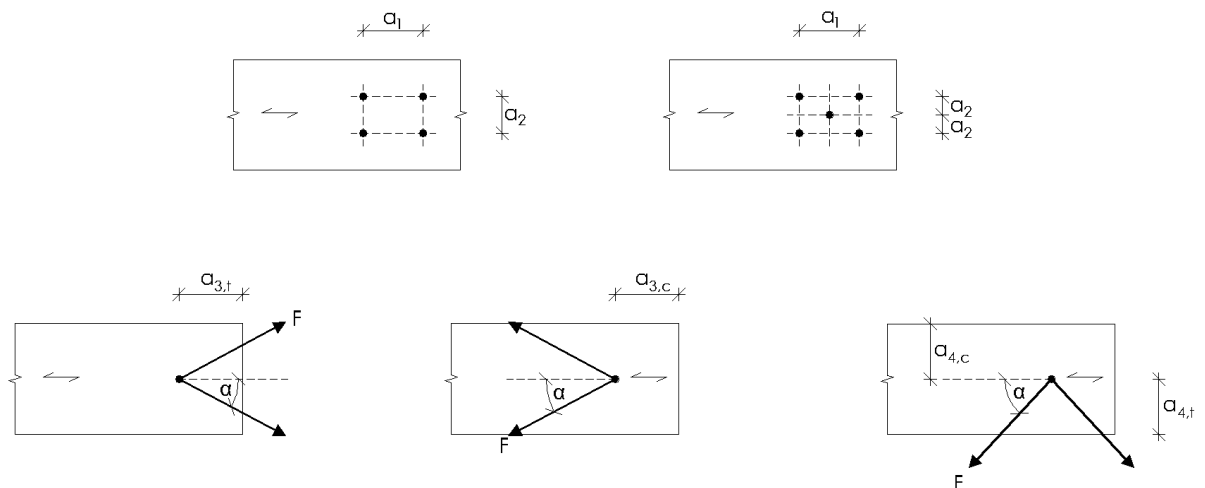

Figure 4: Definition of minimum spacings, edge and end distances for laterally loaded dowel-type fasteners in the plane side of cross laminated timber

Table 4: Definition of minimum spacings, edge and end distances in the plane side of Best wood CLT cross laminated timber

	a_1	$a_{3,t}$	$a_{3,c}$	a_2	$a_{4,t}$	$a_{4,c}$
Nails	$(3+3 \cos \alpha) d$	$(7+3 \cos \alpha) d$	$6 d$	$3 d$	$(3+4 \sin \alpha) d$	$3 d$
Screws	$4 d$	$6 d$	$6 d$	$2,5 d$	$6 d$	$2,5 d$
Dowels	$(3+2 \cos \alpha) d$	$5 d$	$\max \begin{cases} 4 d \cdot \sin \alpha \\ 3 d \end{cases}$	$3 d$	$3 d$	$3 d$
Bolts	$\max \begin{cases} (3+2 \cos \alpha) d \\ 4 d \end{cases}$	$5 d$	$4 d$	$4 d$	$3 d$	2

1.1.2 Joints in the narrow side of cross laminated timber

Embedding strength:

The characteristic embedding strength for self-tapping screws with a diameter $d \geq 8$ mm in the narrow sides of cross laminated timber may be calculated according to equation (2).

$$f_{h,k} = 20 d^{-0.5} \quad \text{in N/mm}^2 \quad (2)$$

Where

d = Nominal diameter of the self-tapping screws in mm

For actions perpendicular to the plane side of the cross laminated timber the possibility of splitting caused by the tension force component perpendicular to the grain, shall be taken into account. Connections with ratios $h_e/h < 0,7$ should be reinforced with fully threaded screws (see example in Figure 5).

Where

h_e = Loaded edge distance to the centre of the most distant fastener

h = Thickness of the cross laminated timber

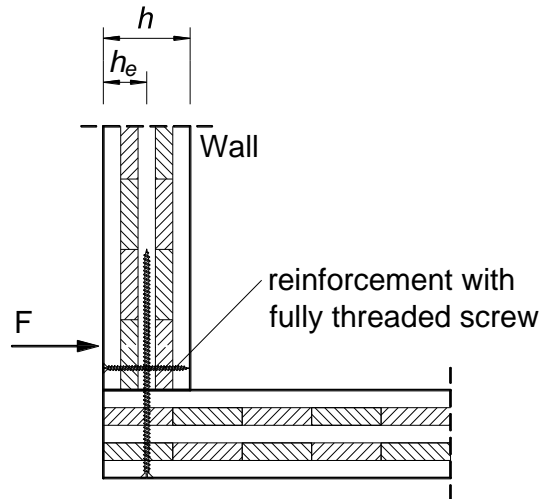

Figure 5: Reinforcement of a cross laminated timber wall with fully threaded screws

Effective number of fasteners:

The effective number of fasteners n_{ef} for solid timber may be used.

Minimum spacing, edge and end distances:

Minimum spacing, edge and end distances as defined in Figure 6 and further requirements for connections with self-tapping screws in the narrow side of cross laminated timber are given in Table 5 and Table 6.

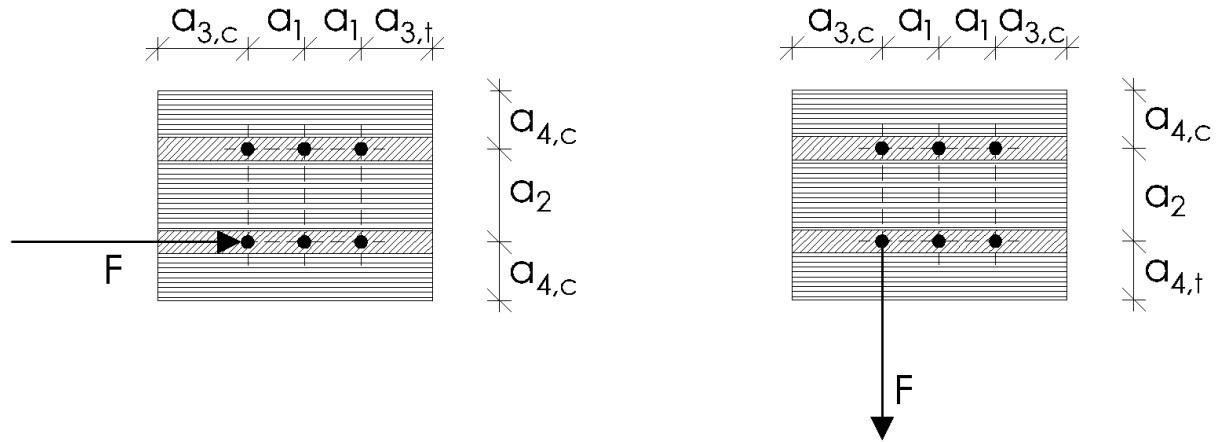

Figure 6: Definition of minimum spacings, edge and end distances for laterally loaded dowel-type fasteners in the narrow side of cross laminated timber

Table 5: Definition of minimum spacings, edge and end distances in the narrow side of cross laminated timber

	a_1	$a_{3,t}$	$a_{3,c}$	a_2	$a_{4,t}$	$a_{4,c}$
Screws	$10 d$	$12 d$	$7 d$	$3 d$	$6 d$	$3 d$

Table 6: Requirements for joints in the narrow side of cross laminated timber

	Minimum thickness of the relevant layer t_{lay} in mm	Minimum thickness of the cross laminated timber t_x in mm	Minimum penetration length of the fastener t_1 or t_2 in mm ^{a)}
Screws	$d > 8 \text{ mm}: 3 \cdot d$ $d \leq 8 \text{ mm}: 2 \cdot d$	$10 \cdot d$	$10 \cdot d$
^{a)} t_1 Minimum penetration length of the fastener in side members t_2 Minimum penetration length of the fastener in middle members			

1.2 Axially loaded dowel type fasteners

1.2.1 Threaded nails

The characteristic withdrawal capacity for threaded nails in the plane sides of Best wood CLT cross laminated timber may be calculated according equation (3).

$$F_{ax,Rk} = 14 d^{0,6} \cdot \ell_{ef} \quad \text{in N} \quad (3)$$

Where

d = Outer diameter of the threaded part

$\ell_{ef,i}$ = Penetration length of the threaded part

The following conditions should be fulfilled:

- At least two nails in a connection
- Diameter of the threaded part $d \geq 4 \text{ mm}$
- Penetration length of the threaded part $\ell_{ef} \geq 8 d$
- Characteristic point side withdrawal parameter $f_{ax,k} \geq 4,5 \text{ N/mm}^2$

1.2.2 Screws

Withdrawal capacity:

The characteristic withdrawal capacity for self-tapping screws in the plane sides or in the narrow sides of cross laminated timber may be calculated according equation (4).

$$F_{ax,Rk} = \sum_{i=1}^n f_{ax,i,k} \cdot l_{ef,i} \cdot d \quad \text{in N} \quad (4)$$

Where

d = Outer diameter of the threaded part, with $d \geq 6$ mm for screws in the plane sides of cross laminated timber and $d \geq 8$ mm for screws in the narrow sides of cross laminated timber

$f_{ax,i,k}$ = Characteristic withdrawal strength of layer i depending on the characteristic density $\rho_{k,i}$ and the angle α_i between screw axis and grain direction of layer i

$l_{ef,i}$ = Penetration length of the threaded part in layer i

n = Number of penetrated layers

The following conditions should be fulfilled:

- Penetration length of the threaded part $l_{ef,i} \geq 4 d$

For the design of axially loaded screws in cross laminated timber only threaded parts with an angle $\alpha \geq 30^\circ$ between screw axis and grain direction may be taken into account.

Screws oriented parallel to the plane side of the cross laminated timber should be completely arranged within one layer. The outer diameter of the threaded part should not exceed the thickness of the layer the screw is arranged in.

The characteristic pull-through strength of the screw head for solid timber may be used, depending on the characteristic density of the lamination at the head side of the screw.

Pushing-in capacity:

The characteristic pushing-in capacity for screws may be calculated according equation (5).

$$R_{ki,k} = \kappa_c \cdot N_{pl,k} \quad \text{in N} \quad (5)$$

Where

$$\kappa_c = \begin{cases} 1 & \text{when } \bar{\lambda}_k \leq 0,2 \\ \frac{1}{k + \sqrt{k^2 - \bar{\lambda}_k^2}} & \text{when } \bar{\lambda}_k > 0,2 \end{cases}$$

$$k = 0,5 \cdot [1 + 0,49 \cdot (\bar{\lambda}_k - 0,2) + \bar{\lambda}_k^2]$$

$$\bar{\lambda}_k = \sqrt{\frac{N_{pl,k}}{N_{ki,k}}}$$

$$N_{pl,k} = \pi \cdot \frac{d_k^2}{4} \cdot f_{y,k} \quad \text{in N}$$

d_k = core diameter of the screw in mm

$f_{y,k}$ = yield strength in N/mm²

$$N_{ki,k} = \sqrt{C_h \cdot E_S \cdot I_S} = \text{buckling load of the screw in N}$$

$$c_h = (0,19 + 0,012 \cdot d) \cdot \rho_k \cdot \left(\frac{90^\circ + \alpha}{180^\circ} \right) = \text{bedding factor in N/mm}^2, \text{ the most adverse combination of } \alpha \text{ and } \rho_k \text{ is relevant}$$

ρ_k = characteristic density of a layer

α = angle between screw axis and grain direction in a layer

$$E_s \cdot I_s = \frac{210000 \cdot \pi \cdot d_k^4}{64} = \text{bending stiffness of the screws core area in N/mm}^2$$

1.3 Connections with split ring connectors and toothed-plate connectors

The characteristic value of the load-bearing capacity of split ring connectors and toothed-plate connectors in the plane sides of cross laminated timber may be calculated according to EN 1995-1-1.

For split ring connectors in the narrow sides of cross laminated timber the regulations for connections with split ring connectors in the end grain may be applied.

Toothed-plate connectors in the narrow sides of cross laminated timber shall not be taken into consideration as load-bearing.